



citadel™

CTD-SS-N TOWED ARRAY

Robust, Reliable, and Rugged CTD

In-Line Sound Velocity Sensor for Towed Arrays

The Citadel CTD-SS-N Towed-Array Sound Velocity Sensor combines innovative sensors and patented electronics to achieve the highest levels of sound velocity accuracy available for towed acoustic streamer arrays. The unit calculates underwater sound velocity based on highly accurate and stable measurements of conductivity, temperature, and pressure. Sensors are incorporated in a novel array insert for direct in-streamer mounting, which ensures free-flushing of the sensors while towing in either direction.

Precise fixed references provide continuous internal calibration of the sound velocity sensor. Calibration constants are stored in non-volatile memory and can be updated remotely, if required. A low-power microcontroller allows for collection, scaling, and real-time transmission of sound velocity data via CMOS, RS-232, or RS-485 interfaces.



The Citadel CTD-SS-N offers:

- *High Accuracy*
 - +/-0.005 SIM conductivity
 - +/-0.005°C temperature
 - +/-0.05% full scale pressure
- *High quality sensors*
 - Highly stable inductive conductivity sensor
 - Highly stable thermistor sensor
 - Titanium strain gauge pressure sensor
- *2.0 frames/second data collection*
- *Low power (200mW)*
- *Direct computed outputs of salinity and sound velocity*
- *Free flushing bi-directional tow sensors, no pump required*
- *Direct digital output, CMOS, RS-232 or RS-485*
- *Internal reference, self-calibrating electronics*
- *Small size, 2.63" O.D.*

**TELEDYNE
RD INSTRUMENTS**

A Teledyne Technologies Company



ROBUST, RELIABLE, AND RUGGED CITADEL CTD'S



Technical Specifications

Sensors				
Parameter	Sound Velocity	Conductivity	Temperature	Pressure
Sensor	Calculated	Inductive Cell	Aged Thermistor	Precision Micro-Machined Silicon
Range	1400-1609 m/s	0-7.0 S/m 0-70 mS/cm	-2° to 32°C	Customer specified
Accuracy	±0.20 m/s	±0.005 S/m ±0.050 mS/cm	±0.01°C	0.05% full scale
Stability	0.02 m/s	±0.0005 S/m/month ±0.005 mS/cm/month	±0.003°C/month	±0.005% full scale/month
Resolution	±0.01 m/s	0.0001 S/m 0.001 mS/cm	0.001°C	0.001% full scale
Response	25.0 cm at 1 m/s	25.0 cm at 1 m/s	100 m/s	25 m/s

Instrument

Power:	6 to 14 VDC at 20 mA, 120 mW maximum
Depth Rating:	600-meter electronics housing
Dimensions:	2.63" O.D. (Consult factory for interface specifications and custom configurations.)
Sample Rate:	Fixed 2.0 frames/second-CTD, salinity, sound velocity
Resolution:	20 bits A/D
Computations:	Salinity & sound velocity UNESCO-44 (PSS-78 & Millero Chen 77)
Data Formats:	Conductivity - mS/cm Temperature - C (ITS-90) Pressure - decibars Salinity - PSU (Practical Salinity Units) Sound Velocity - m/sec All data in ASCII, 8 data bits, one stop bit, no parity CMOS or RS-232 or RS-485
Baud Rate:	Fixed 9600 Baud
Calibration:	NIST Traceable @ FSI Per UNESCO 44 Requirements

Dimensions

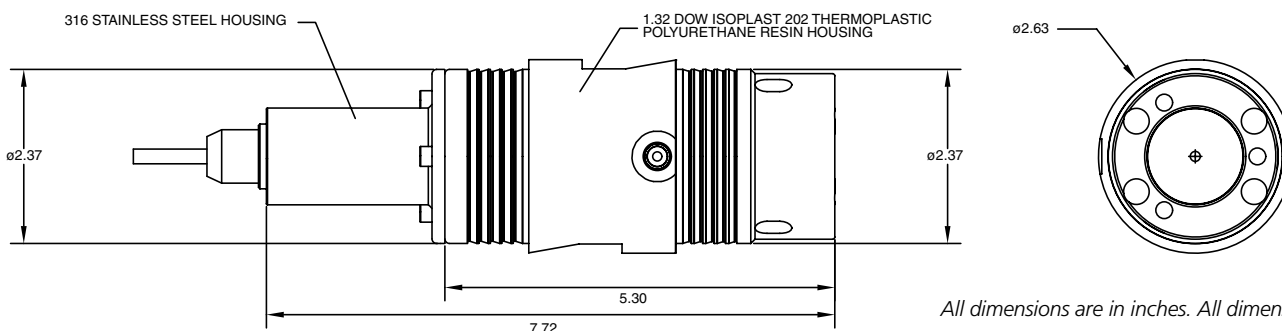

All dimensions are in inches. All dimensions are subject to change.